



AQUA TEK
INNOVATIVE WATER PRODUCTS
**ATAIOIF SERIES CHEMICAL FREE
IRON & SULFUR FILTER**

ATAIOIF

Operation & Maintenance Manual

Table of Contents

Introduction	4
About Your Filter	5
Installation Guide	6
Media Fill/Replacement	8
System Startup	9
Programming	10
Manual Regeneration	12
Bypassing Filter	13
Trouble Shooting Guide	14
Manufacturer's Limited Warranty	16

ATTENTION

ATAIOIF System Specifications & Warnings

System Specifications

Water pressure: 40 psi minimum 100 psi

Maximum Water Temperature: 40°F to 95°F

Electrical Requirements:

Supply Voltage: 120V

Supply Frequency: 60Hz

Output Voltage: 12V AC

Output Current: Maximum 3.0 Amps

Water Meter:

Pipe Size: 3/4"-1"

Accuracy: ± 5%

Minimum Flow : 0.25 GPM

Control Valve to Tank Connection: 2.5"-8UN Control

Valve Distributor Pipe Connection: 1"

Circuit Board Memory: Non-volatile EEPROM (Electrical Erasable Programmable Read Only Memory)

Compatible with the following typical concentrations of regenerant chemicals: Sodium Chloride, Potassium Chloride, Potassium Permanganate, Sodium Bisulfite, Chlorine and Chloramines



WARNINGS



- ① The control valve and fittings are not designed to support the weight of the system or the plumbing.
- ① Do not use Vaseline, oils, other hydrocarbon lubricants or spray silicone anywhere. A silicone lubricant may be used on black O-rings. Hydrocarbons such as kerosene, benzene, gasoline, etc., may damage products that contain O-rings or plastic components. Exposure to such hydrocarbons may cause the products to leak. Do not use the product(s) contained in this document on water supplies that contain hydrocarbons such as kerosene, benzene, gasoline, etc.
- ① The water meter should not be used as the primary monitoring device for critical or health effect applications.
- ① Do not use pipe dope or other sealants on threads. Teflon tape is recommended to be used on all threads. Use of pipe dope may break down the plastics in the control valve.
- ① This system is not intended for use where water is microbiologically unsafe or with water of unknown quality.
- ① **WARNING!** Electrical Shock Hazard! Prior to servicing equipment, disconnect power supply.
- ① If incorrectly installed, operated or maintained, this product can cause injury or property damage. Those who install, operate, or maintain this product should be trained in its proper use and should read the entire manual before attempting to install, operate, or maintain this product.

Introduction

Please Read Manual First

Before you operate your Aquatek Iron Filter, read this manual to become familiar with the device and its capabilities.

Installation or maintenance done on this system by an untrained service person can cause major damage to equipment or property damage. Not adhering to the recommended service/maintenance can cause damage to equipment or property damage. It is important to maintain your sulfur and iron filter. To properly maintain your system have a water technician change the filter media when necessary. (Check with your dealer.) If your filter media is not working properly, or is not replaced frequently enough, it has potential to grow bacteria that can end up in your water system. A water technician can tell you how often the filter media needs replacing.

This manual is intended to be a practical reference guide. It contains information about operating this water filtering system—including installation and start-up instruction for the installer and programming, regenerations, settings and troubleshooting for the homeowner. The Sulfur and Iron Water Filter is designed for long-term use. To determine when to change the filter media, contact your dealer. Every system encounters different water conditions therefore every filtration system will have different timetables for replacing the filter media. Make sure you have a water technician change your filter media and periodically test for effectiveness.

Zeolite

Background

Zeolite filter media offers advantages over conventional sand, sand & anthracite or multimedia for gravity flow or pressure vessel beds. Historically, natural zeolite mineral deposits were discovered in the 1950's and zeolite has been quarry, mined, crushed, air-drying and sieve sized to produce commercial products for >30 yrs. Natural zeolite (Clinoptilolite) is crystalline, aluminum oxide/silicon oxide classified as a crystalline, molecular sieve, mineral consisting of hydrated Ca_2 (Na_2 or K_2) $\text{Al}_8 \text{Si}_{28} \text{O}_{72} \cdot 24 \text{H}_2\text{O}$. Most zeolite deposits are low quality and can't be used as molecular sieve beds or water filtration media. Zeolite has been used for water softening and to remove NH_4 ion using slow flow rates (1-2 gpm/ft²) and Na-ion regeneration cycles. Since 1985 numerous technical and engineering studies have demonstrated the utility of zeolite mineral as an effective water filter media.

Zeolite Filter Media

Zeolite Filter Granules are a high quality, granular, filter media that achieves superior filtration & solids loading compared to conventional filter media. The zeolite media is from a unique, mineral deposit in the western USA having high porosity, hardness, high surface area (~28m²/gm) and surface, micromineral, projections that make it an ideal water filtration media (fig 2 & 3).. The 14 x 40 mesh filter media has a dry bulk wt.55 lb/ft³ & is attrition resistant. The zeolite mineral is classified under 21CFR Part 182.2729 & 40 CFR Part 180. as GRAS (Generally Recognized As Safe) and is NSF Standard 61 Listed.

About Your Filter

How Does my Sulfur and Iron Filter Work?

This filter uses a special blend of calcium, magnesium oxide and sand that is highly effective for removal of hydrogen sulfide and iron. The filter uses an air chamber within the tank to capture and oxidize the elements and then filter them through the media bed. An automatic backwashing system will clean the media of the sulfur and iron leaving the system clean, and the water you drink odor free.

A Control Valve



B Mineral Tank

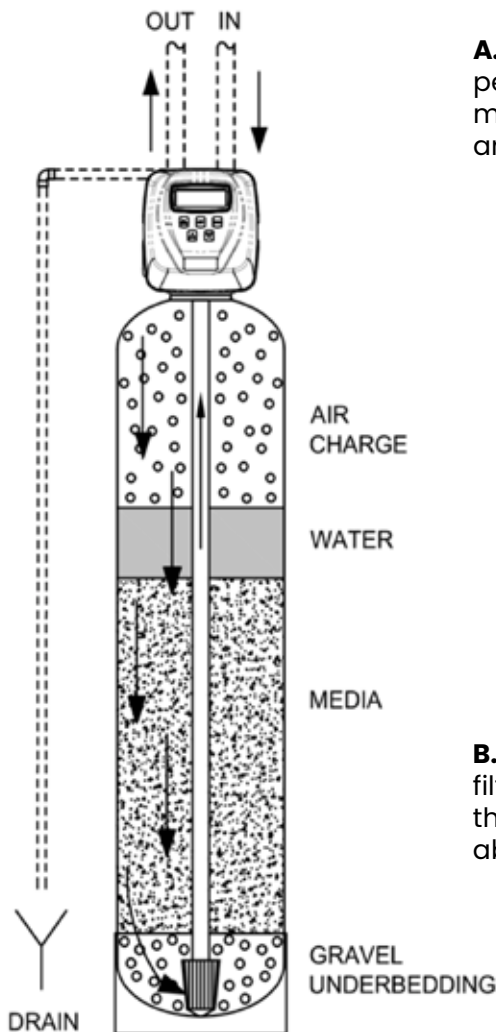

All Aquatek Iron Filters are comprised of two primary components: **(A)** Control Valve, **(B)** Mineral Tank.

A. Control Valve: Your control valve automatically performs the 3 primary operations which are commonly referred to as cycles. These operations/cycles are:

- 1. Pre-Treatment Oxidation:** Air is injected into the mineral tank which causes contaminants in the water to precipitate and settle out. Precipitated contaminants are much larger and clump together so they can be removed through filtration.
- 2. Service / Filtration:** The oxidized water is now flushed through the media bed comprised of ZeoLite¹ (see pg 4) and gravel underbedding which mechanically strains the contaminants like iron, manganese, & hydrogen sulfide.
- 3. Backwash:** Once the media bed has reached its predetermined limit of filtration it cleans and replenishes itself through backwashing. Backwashing is a forceful flush that removes the filtered contaminants and then flushes them down the drain.

B. The Mineral Tank: The mineral tank contains the filtration media and is where the treatment of the water takes place during the 3 stages mentioned above.

Installation Guide

Pre-Installation Checklist

1. A standard electrical outlet (120V/160Hz) must be located within 12' of installation site.
2. A functioning floor drain, washer sand pipe or suitable location for waste water discharge must be located within 20' of installation site.
 - a. All plumbing should be done in accordance with local plumbing codes. The pipe size for the drain line should be a minimum of 1/2". Backwash flow rates in excess of 7 gpm or length in excess of 20' require 3/4" drain line.
3. It is recommended a working pressure reducing valve be installed on the inlet water line that supplies the water filter
4. **Note: The warranty is void if the system is exposed to water pressure in excess of 100 psi and/or water temperatures in excess of 95° F**
5. **Important:** Protect your Filter and the entire drainline from freezing temperatures. The temperature at the location of the system should never be below 40° F



WARNING! DANGER: If your unit should freeze, do not attempt to disassemble it. Call us first 877-414-PURE



Installation

1. Floor Space: Make sure the floor space that has been selected to install the water filter is clean and on a level surface. In some cases, your media may be shipped separately. Place media Tank in relative position of end install, and see "Media Fill/Replacement" on page 8.

2. Leveling the System: Mineral tanks are fitted with an adjustable leveling base, if tank is not vertical/straight lift tank 1-3 inches off the floor and gently release tank back on to the floor (repeat until straight up and down).

3. Connection Kit: The standard connection kit supplied with the water softener will be a 1" plastic elbow connection kit. (See Figure 1) Other connection kits are available.

4. Plumbing Preparations: Unscrew the two plastic nuts (#1) and pull on the two brass connectors (#4) to remove them from the bypass assembly. Next remove the white plastic rings (#2) and the O-rings. (#3) (See Figure 2)

- Solder at least 6" of pipe to the brass connectors before reassembly. (See Figure 2)
- After soldering is complete, cool the pipe and connectors. Slide the plastic nuts (#1) over the brass connectors (#4). Place the white plastic split rings (#2) into the grooves closest to the end of the brass connectors (#4). Reassembly the connection kit onto the bypass assembly.

Warning: When assembling the installation-fitting package (inlet and outlet), connect the fitting to the plumbing system first and then attach the nut, split ring and O-ring. Heat from soldering or solvent cements may damage the nut, split ring or O-ring. Solder joints should be cool and solvent cements should be set before installing the nut, split ring and O-ring. Avoid getting primer and solvent cement on any part of the O-rings, split rings, bypass valve or control valve.

5. Plumbing: When connecting the water filter to the existing plumbing, make sure the inlet water is connected to the inlet of the filter. Arrows on the valve body indicate direction of flow. Make sure the bypass valves are in the correct position See Figure 3. An internal check valve is supplied with the system and has already been installed in the inlet of the control valve to ensure that the air charge in the top of the tank does not escape backwards out the inlet.

Note: All plumbing should be done in accordance with local plumbing codes.

Warning: The control valve, fittings and/or bypass are designed to accommodate minor plumbing mis-alignments but are not designed to support the weight of a system or the plumbing.

Installation CONT.

6. Locate Polytube Insert: Now that the water softener is connected to the existing plumbing, the drain line may be connected. First, locate and remove the polytube insert (#2) from the gray cable on the left side of the control valve. (See Figure 4)

7. Connecting the Drain Line: Slide plastic nut (#3) over the permanent drain tubing and place the polytube insert (#2) into the end of the drain tubing. Insert the drain tubing into the drain elbow fitting (#4) and tighten plastic nut (#3) hand-tight plus 1/2 turn with pliers. Caution: Do Not Over-tighten. (See Figure 4)

8. Drain Line Specs: If the distance from the water filter to the drain is greater than 20' the drain line size must be increased to 3/4". The threads on the drain elbow fitting are 3/4" male NPT and can be used in lieu of the 1/2" plastic nut and insert. If the drain line must run overhead, the maximum height of the drain line should not exceed 8' above the top of the water softener.

9. Air Gap: The drain line must have an approved air gap to prevent the possibility of a cross connection to the sewer. (See Figure 5)

10. IMPORTANT: Special precautions must be made when connecting the drainline. During backwash, high volumes of air and water escape rapidly, causing a flexible drain line to whip and thrash. Rigid drain piping is highly recommended.



Disclaimer United Water strongly recommends that each system be installed by a licensed and knowledgeable professional. Failure to do so could result in property damage, equipment failure and potentially void warranty.



All systems MUST be installed in accordance with local and state plumbing codes.

Fig. 1

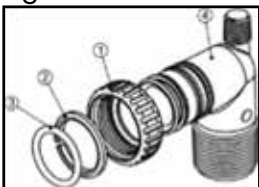

Fig. 3

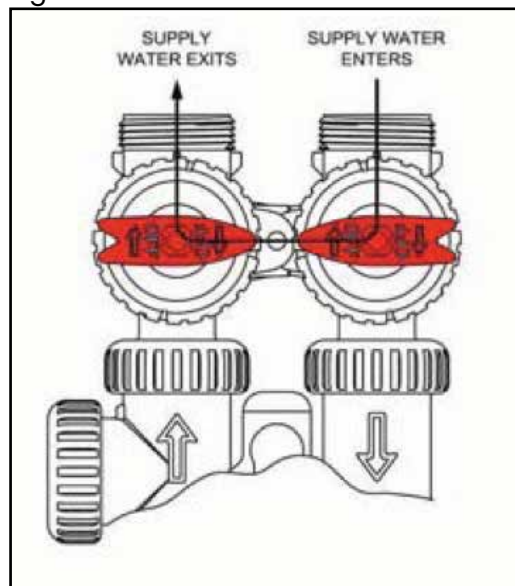

Fig. 4

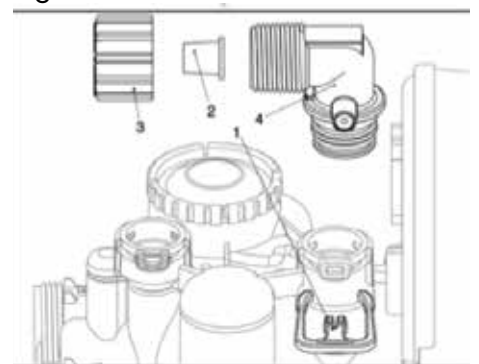

Fig. 2 (optional)

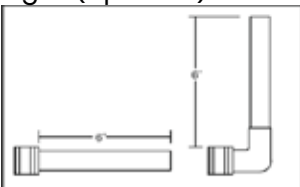
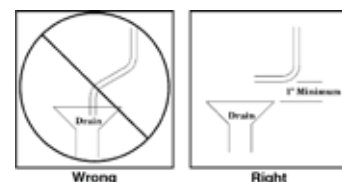

Fig. 5



Media Fill/Replacement

These instructions are to help guide you through the steps for initial installation or replacement of the media in your filter or softener. Please check to ensure that all the parts have been included by reviewing the labels that are attached to the filter (e.g. xxx bed - container 1 of 3, 2 of 3, 3 of 3). Container may contain more than one media. If you have any questions regarding the installation or replacement of your media bed, please contact your local dealer for assistance.

1. Loading the Media Pak

Place the distributor tube into the media tank and plug the end of the distributor tube with a tape to prevent media from entering it. Make sure that distributor tube is inside the tank and seated in a depression at the bottom of the tank. (If replacing the media, inspect the distributor for any damage to the slots in the cone or plugging - clean if necessary.)

Plug tube with a tape
Remove after media
is loaded.



Fig. 1 - The riser (distributor) remains inside the tank seated in the depression at the bottom. The riser should be capped to prevent resin beads from getting inside.



Fig. 2 - Fill support bed first (if supplied)



Fig. 3 - The media will not always spill down inside the tank and may need to be swept inside

Plug the media tube with tape to prevent the media from getting inside the tube. Place the media into the tank in the order indicated on the next page for the type of unit that matches yours. The large funnel (supplied) makes filling the tank easier and heater. (Or an empty 1 gallon or 4 liter container with the bottom cutout makes a good funnel.) Fill support bed (if supplied) first. During the filling process, ensure the distributor tube stays on the bottom of the tank, reasonably centered. Remove the tape from the distributor once media is loaded. Whenever possible, fill the tank outdoors to avoid problems with dust. If filling indoors, a dust mask should be worn.



2. Placing the Unit in Service

Once the tank is filled, remove the cover from the distributor and clean off the top of the tank. Place the control valve onto the tank, ensuring the distributor fits into the valve properly. Tighten the valve onto the tank using moderate force. Applying some household liquid soap to the main seal O-ring will ease assembly. Attach the plumbing to the inlet and outlet of the valve as necessary. Follow the installation and operating instructions for system start-up found in your Owners Manual or slowly fill the tank in the backwash position and allow it to flush the air and fine particles down the drain until the drain water appears clear (about 20 minutes). Once the drain runs clear, plug in the electrical cord, open the inlet valve fully and allow the valve to finish its cycle. Check for any leaks and reset the time of day on your controller.

3. Depressurizing the Unit*

The first step is to loosen the bed and depressurize the unit. Place the unit into the backwash position and keep it there by unplugging the unit from the power supply. Allow it to backwash for several minutes to loosen the bed. To depressurize, simply shut off the water supply to the unit either at the main or use the bypass to the unit.

4. Removal of Old Media*

Next remove the control valve and empty the tank. You may have to disconnect plumbing from the inlet and out let of the valve. depending on the type of valve your filter or softener has. insert a piece of 1/2" flexible hose into the distributor and siphon the water into the drain. Remove the distributor tube from the tank. Flush out all the contents into a large pail or garbage can by elevating the tank as required (dictated by container used to hold old media). Lay the tank on its side and insert a garden hose into the tank. Make sure the tank is completely empty before proceeding.

* for replacement of media only

System Start-Up



*****NOTE***** In situations where there are multiple systems being started/used it is imperative that each system be started independently AND place all other systems not being started in bypass to avoid flushing debris/contaminates across systems



Start-Up

1. Make sure the bypass is in the position shown in Figure 1.
2. Open a faucet that is being supplied by the water filter. Air and discolored water will be discharged from the faucet.
3. Leave faucet running until water runs clear and turn off faucet.
4. Let the media stand for at least fifteen minutes. This will help saturate the media inside the filter.

Note: Failure to follow the above instructions could result in the media plugging the filter controller.

5. Set the clock to the current time of day. (See Page 11)
6. Start the filter into the manual regeneration cycle. (See Page 12)
7. Push and hold the REGEN button for approximately 6 seconds.
8. Leave the filter in the regeneration cycle to create the air charge necessary for proper function of the filter.

Start-Up of your filter is complete.

Fig. 1

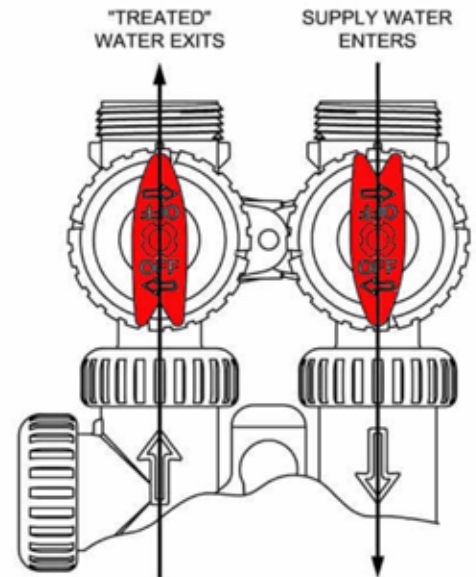

Programming Guide

Aquatek ATAIOF Iron Filter Control Valve Programming & Operation



Setting The Time of Day

Your unit will come with the correct time setting when a water technician installs it. After that, time of day should only need to be set if there is a power outage or when daylight saving time begins or ends. If an extended power outage occurs the time of day will flash indicating that it needs to be reset.

Step 1: Press SET CLOCK. The hour display will be flashing.

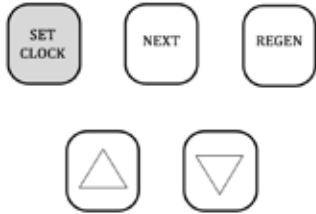
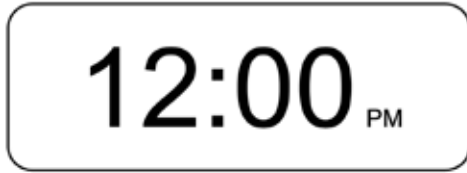

Step 2: Set the correct hour by pressing either the **UP** or the **DOWN** arrow buttons. The PM indicator arrow will appear when the hour reaches 12 PM

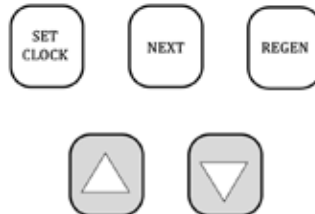
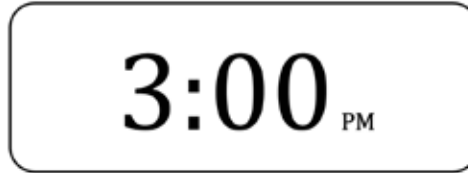

Step 2: Press **SET CLOCK** button again to set the minutes. The minute display will then flash. Adjust the minutes using the UP or the DOWN arrow buttons.

Step 4: Press **SET CLOCK** to complete..

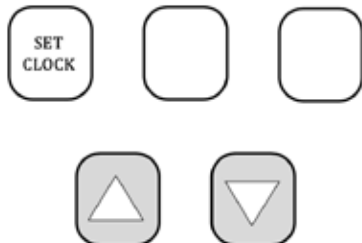
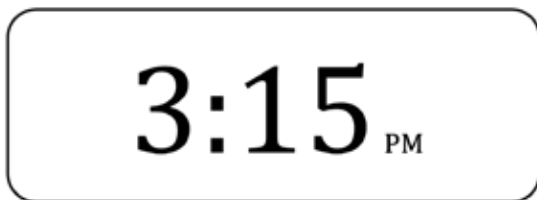

Manual Regeneration

To initiate manual a regeneration press and hold the REGEN button approximately 6 seconds.



The regeneration process consists of two cycles. The first cycle is ten minutes long and the second cycle is sixty minutes long making the entire regeneration a total of seventy minutes long.



Once the unit begins the manual regeneration the display will read the time remaining for each cycle. When the filter has completed the manual regeneration the system will automatically return to its preset normal operations.

Bypassing Filter

Bypassing the filter will reroute the unfiltered water to the fixtures in the house. In effect, your water is no longer filtered. Bypassing the filter is only necessary to isolate the filter in case of contamination, repairs and to stop leaks.

Control Valve in Service Mode

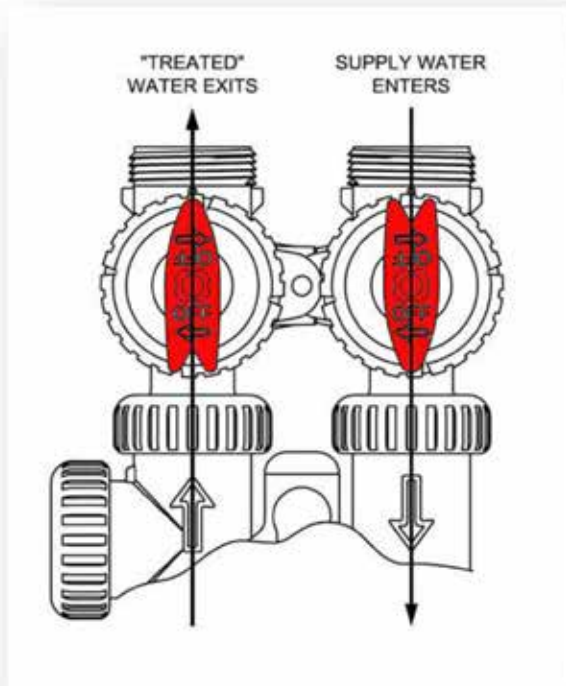

Control Valve in the Bypass Mode

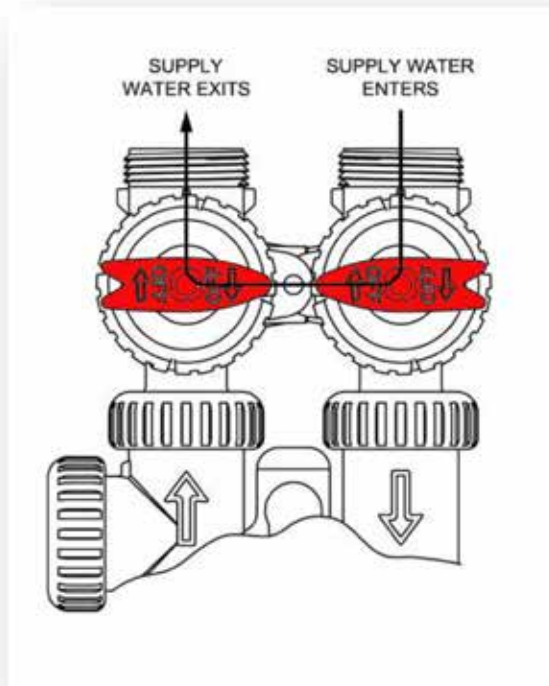

Step 1:

Locate the bypass valve on your filter. It will have two red handles in the shape of arrows. The handle on the left will be facing **AWAY** from the unit. The red handle on the right will be facing **TOWARD** the unit. This indicates that the unit is in the **SERVICE MODE**.

Step 2:

To set the unit in the **BYPASS MODE**, turn both red handles so that they are facing each other. This prevents unfiltered water from entering the unit and reroutes it directly to the fixtures in the house.

Bypassing the filter will allow unfiltered water into your home. Bypassing is for emergencies or service only!

Trouble Shooting Guide

Problem	Possible Cause	Solution
Timer does not display time of day	Transformer unplugged	Connect power
	No electrical power at the outlet	Repair outlet or use working outlet
	Defective Transformer	Replace transformer
	Defective PC board	Replace PC Board
The Timer does not display the correct time of day	Switched outlet	Use uninterrupted outlet
	Power outage	Reset time of day
	Defective PC board	Replace PC board
Control valve back-washes at the wrong time of day	Time of day is not set correctly	Reset to correct time of day
	Time of backwash is set incorrectly	Reset backwash time
	Power outage	Reset valve to correct time of day
The unit is leaking	Fittings are loose	Tighten fittings
	The tank is cracked	Bypass unit (See pg. 13)
	Damaged drain line or hose	Replace drain line or hose
Reduced water flow or pressure	Breakdown of the media	Bypass unit (See pg. 13) and replace the media. Contact us to replace media - 877-414-PURE
	Media has begun to solidify	
	Overload of sediment or clogging of media	
Control valve stalled in the backwash	Motor not operating	Replace motor
	No electrical power at outlet	Repair or use working outlet
	Defective transformer	Replace transformer
	Defective PC board	Replace PC board
	Broken piston retainer	Replace drive cap assembly
	Broken main or regenerant piston	Replace main or regenerant piston
	Broken drive gear or drive cap assembly	Replace drive gear or drive cap assembly
Control valve does not automatically back-wash when REGEN button is depressed and held	Transformer unplugged	Connect transformer
	No electrical power at outlet	Repair or use working outlet
	Broken drive gear or drive cap assembly	Replace drive gear or drive cap assembly
	Defective PC board	Replace PC board
Control valve does not automatically back-wash but does when REGEN button is depressed and held	Defective PC board	Replace PC board
	Set-up error	Check control valve set-up procedure

Problem	Possible Cause	Solution
Err - 1001 = Control unable to sense motor movement	Motor not inserted full to engage pinion, motor wires broken or disconnected	Disconnect power, make sure motor is fully engaged, check for broken wires, make sure two pin connector on motor is connected to the two pin connection on the Circuit Board labeled MOTOR. Press NEXT and REGEN buttons at the same time for 3 seconds to resynchronize software with piston.
	Circuit Board not properly snapped into drive bracket	Properly snap Circuit Board into drive bracket and then Press NEXT and REGEN buttons at the same time for 3 seconds to resynchronize software with piston.
	Missing reduction gears	Replace missing gears
Err - 1002 = Control valve motor ran too short and was unable to find the next cycle position and stalled	Foreign material is lodged in control valve	Open up Control Valve and pull out piston assembly and Seal and Spacer Stack Assembly for inspection. Press NEXT and REGEN buttons at the same time for 3 seconds to resynchronize software with piston.
	Mechanical binding	Check Piston and Seal and Spacer Stack Assembly, check Reduction Gears, check Drive Bracket and Main Drive Gear Interface. Press NEXT and REGEN buttons at the same time for 3 seconds to resynchronize software with piston.
	Main Drive Gear too tight	Loosen Main Drive Gear. Press NEXT and REGEN buttons at the same time for 3 seconds to resynchronize software with piston.
	Improper voltage being delivered to Circuit Board	Verify that proper voltage is being supplied. Press NEXT and REGEN buttons at the same time for 3 seconds to resynchronize software with piston.
Err - 1003 = Control valve motor ran too long and was unable to find the next cycle position	Motor failure during a regeneration	Check motor connections then Press NEXT and REGEN buttons at the same time for 3 seconds to resynchronize software with piston.
	Foreign matter built up on Piston and Seal and Spacer Stack Assemblies creating friction and drag enough to time out Motor	Replace Piston and Seal and Spacer Stack Assemblies. Press NEXT and REGEN buttons at the same time for 3 seconds to resynchronize software with piston.
	Drive Bracket not snapped in properly and out enough that reduction gears and drive gear do not interface	Snap Drive Bracket in properly then Press NEXT and REGEN buttons at the same time for 3 seconds to resynchronize software with piston
Err - 1004 = Control valve motor ran too long and timed out trying to reach home position	Drive Bracket not snapped in properly and out enough that reduction gears and drive gear do not interface	Snap Drive Bracket in properly then Press NEXT and REGEN buttons at the same time for 3 seconds to resynchronize software with piston.

Manufacturer's Limited Warranty

The manufacturer warrants to the original owner that its Water Conditioning Equipment will be free from defects in material and workmanship under normal use and service for a period of five (5) years from the date of installation, when installed and operated within recommended parameters. No warranty is made with respect to defects not reported to Manufacturer within the warranty period and/or defects or damages due to neglect, misuse, alterations, accident, misapplication, physical damage, or damage caused by fire, floods, acts of God, freezing or hot water or similar causes. Manufacturer's obligation to the owner of this equipment under this Limited Warranty shall be limited, at its option, to replacement or repair of this Water Conditioning Equipment.

To obtain warranty service mail or ship the defective parts freight prepaid to the Manufacturer's place of business. Manufacturer will, at its option, repair or replace the defective components at its expense and return parts freight collect.

Manufacturer gives this warranty to the owner in lieu of all other warranties, express or implied, including without limitation any implied warranties of merchantability or fitness for a particular purpose and hereby expressly disclaims all other such warranties. Manufacturer's liability hereunder shall not exceed the cost of the product. Under no circumstances will Manufacturer be liable for any incidental or consequential damages or for any other loss, damage or expense of any kind, including loss of profits, arising in connection with the installation or use or inability to use this product.

To obtain warranty service contact:

United Water

12427 NE 117th Ave Suite 105

Vancouver WA 98662

877-414-7873

unitedwatercorp@gmail.com

www.unitedwaterinc.com