



**AQUA TEK**  
INNOVATIVE WATER PRODUCTS

**ATUN-SERIES**

**UPFLOW NEUTRALIZERS**

**ATUN1001 | ATUN1501 | ATUN2001**

**Operation & Maintenance Manual**

# Table of Contents

Introduction	4
About Your ATUN	5
Installation Guide	6
Parts & Components	8
Trouble Shooting Guide	9
Manufacturer's Limited Warranty	10

# \*\*\* ATTENTION \*\*\*

## Specifications

Model Number	Flow Rate @ 15 psid	Pipe Size	Electrical	Media Bed Material	Media Bed Cu. Ft.	Mineral Tank Diameter	Mineral Tank Height	Total System Size (in)
ATUN1001	6	1" NPT Elbow	Not req.	Calcite	1	9"	48"	12 x 12 x 58
ATUN1501	7.5	1" NPT Elbow	Not req.	Calcite	1.5	10"	52"	13 x 13 x 62
ATUN2001	9	1" NPT Elbow	Not req.	Calcite	2	12"	54"	15 x 15 x 64

Maximum operating temperature 110°F (43.3°C); Maximum operating pressure 20-100 psi. Specifications subject to change without notice.

### NOTES:

\* The lower the pH (acidity) of the water being treated, the greater the attrition rate of the media and the slower the water should pass through the bed. The unit should be sized according to the level of pH and existing flow rate.



# \*\*\* WARNINGS \*\*\*



- ① To reduce the risk of choking: DO NOT allow children under the age of 3 years of age to have access to small parts during the installation of this product.
- ① This system is not intended for use where water is microbiologically unsafe or with water of unknown quality.
- ① To reduce the risk of physical injury: Shut off inlet water supply and depressurize system as shown in manual prior to service.
- ① Read and follow Use instructions before installation and use of this water treatment system.
- ① Installation and use MUST comply with existing state or local plumbing codes. Use flexible tubing connections to connect the valve to household plumbing (as shown in schematic).
- ① Protect from freezing, relieve pressure and drain system when temperatures are expected to drop below 33°F (0.6°C).
- ① Do not install systems in areas where ambient temperatures may go above 110°F (43.3°C).
- ① Do not install on hot water supply lines. The maximum operating water temperature of this Acid Neutralizer System is 110°F (43.3°C).
- ① Do not install if water pressure exceeds 100 psi (689 kPa). If your water pressure exceeds 80 psi (552 kPa), you must install a pressure limiting valve.
- ① Do not install where water hammer conditions may occur. If water hammer conditions exist you must install a water hammer arrester.
- ① Where a backflow prevention device is installed on a water system, a device for controlling pressure due to thermal expansion must be installed.
- ① Do not use a torch or other high temperature sources near Acid Neutralizer System, cartridges, plastic fittings or plastic plumbing.
- ① On plastic fittings, never use pipe sealant or pipe dope. Use PTFE thread tape only, pipe dope properties may deteriorate plastic.
- ① Take care when using pliers or pipe wrenches to tighten plastic fittings, as damage may occur if over tightening occurs.
- ① Do not install in direct sunlight or outdoors.
- ① Mount system in such a position as to prevent it from being struck by other items used in the area of installation.
- ① Ensure all tubing and fittings are secure and free of leaks.
- ① SHUT OFF FUEL OR ELECTRIC POWER SUPPLY TO WATER HEATER after water is shut off.
- ① Do not install system where water lines could be subjected to vacuum conditions without appropriate measures for vacuum prevention.
- ① Do not apply heat to any fitting connected to Bypass or Control Valve as damage may result to internal parts or connecting adapters.
- ① Install on a flat/level surface. It is also advisable to sweep the floor to eliminate objects that could pierce the media tank.
- ① If the home electrical system requires use of the cold water system as an electrical safety ground, a jumper must be used to ensure a sufficient ground connection across the Acid Neutralizer System installation piping — refer installation to qualified personnel.

# Introduction

## **Please Read Manual First**

Before you operate your Aquatek ATUN Upflow Neutralizer, read this manual to become familiar with the device and its capabilities.

Installation or maintenance done on this system by an untrained service person can cause major damage to equipment or property damage. Not adhering to the recommended service/maintenance can cause damage to equipment or property damage. It is important to maintain your system. To properly maintain your system have a water technician change the filter media when necessary. (Check with your dealer.) If your filter media is not working properly, or is not replaced frequently enough, it has potential to grow bacteria that can end up in your water system. A water technician can tell you how often the filter media needs replacing.

This manual is intended to be a practical reference guide. It contains information about operating this system—including installation and start-up instruction for the installer and programming, regenerations, settings and troubleshooting for the homeowner. To determine when to change the filter media, contact your dealer. Every system encounters different water conditions therefore every filtration system will have different timetables for replacing the filter media. Make sure you have a water technician change your filter media and periodically test for effectiveness.

### **MAINTENANCE AND CARE**

It is important to maintain your filter. To properly maintain your system have a water technician change the filter media when necessary. (Check with your dealer.) If your filter media is not working properly, or is not replaced frequently enough, it has potential to grow bacteria that can end up in your water system. A water technician can tell you how often the filter media needs replacing.

# About Your ATUN

## How Does my Neutralizer Filter Work?



The low pH (acid) water passes through a special limestone neutralizing media and slowly dissolves the media raising the pH to approximately 7 units (neutral) or higher. Periodic media replenishment is therefore required. The frequency and amount of media replenishment depends on the volume of water used and how acidic the water is before treatment. The lower the pH (acidity) of the water being treated, the greater the attrition rate of the media and the slower the water should pass through the bed. The unit should be sized according to the level of pH and existing flow rate. Your dealer can provide an estimate of your replenishment requirements.

ATUN Series Upflow Acid Neutralizers virtually eliminate the possibility of media bed “cementing” because the water to be treated actually “up-flows” through the neutralizer media bed! This procedure requires NO electricity or backwashing.

A large fill-port permits easy replenishment of the “sacrificial” neutralizing media by the homeowner or a service technician.

There are different media types available which can be used in this ATUN Series Upflow Acid Neutralizer System. Each is designed to improve a particular aesthetic problem. None of them should be used to make non-potable water safe to drink. The following descriptions indicate not only what the media is designed to do, but also points out their limitations.

### Neutralizer Blend

Neutralizer media is typically a blend of calcium carbonate and magnesium oxide. This media is used to elevate the pH of acid water and is generally used when the pH is approximately 5.5 - 6.0 units. The neutralizer media dissolves when water with a low pH passes through. The blend is used to take advantage of the fast, vigorous pH adjusting capabilities of magnesium oxide and the slow, long-lasting capabilities of the calcium carbonate. Neutralizer is typically not recommended when the pH of the raw water is below 5.5 units, because the dissolve rate would be high and thus constant maintenance of the ATUN Series Acid Neutralizer System would be necessary. In these cases contact our Customer Service Department at 1-877-414-7873 for recommendations.

**\*\*\*NOTE\*\*\*** Since the neutralizer media dissolves as it elevates pH level, it will increase the hardness of your water. If your dwelling contains a tankless water heater, a water softener must be installed after the ATUN Series Upflow Acid Neutralizer System to help prevent the heater coil from plugging with hardness material.

### Calcium Carbonate

Calcium carbonate can be used when only a slight pH adjustment is required (typically 6.0 to 6.8 units). Calcium carbonate is sacrificial (dissolves) when adjusting pH and will thus increase hardness as well. Replenishment will be required periodically, once again depending on raw water pH and water consumption.

**\*\*\*NOTE\*\*\*** Since both calcium carbonate and magnesium oxide increase hardness of your water, if your dwelling contains a tankless water heater, it is recommended that a water softener be installed after the ATUN Series Upflow Acid Neutralizer System to help prevent the heater coil from plugging with hardness material.

# Installation Guide

## Pre-Installation Checklist

1. Installation site is level, clean & cleared of obstructions.
2. It is recommended\* a working pressure reducing valve be installed on the inlet water line that supplies the water filter.
- 3. Note: The warranty is void if the system is exposed to water pressure in excess of 100 psi and/or water temperatures in excess of 110° F**
4. **Important:** Protect your Filter and the entire drainline from freezing temperatures. The temperature at the location of the system should never be below 40° F



**WARNING! DANGER: If your unit should freeze, do not attempt to disassemble it. Call us first 877-414-PURE**



## Installation

- 1. Floor Space:** Make sure the floor space that has been selected to install the system is clean and on a level surface. In some cases, your media may be shipped separately. (see next page)
- 2. Installation Sequence (Fig 1):** Refer to Typical Installation Sequence for correct placement of neutralizer in relationship to other water treatment devices. Installation location is critical because it may change the effectiveness of other products.
- 3. Leveling the System:** Mineral tanks are fitted with an adjustable leveling base, if tank is not vertical/straight lift tank 1-3 inches off the floor and gently release tank back on to the floor (repeat until straight up and down).
- 4. Shut off:** Be sure to shut off water at main supply. On a private well system, turn off power to pump and drain pressure tank. Make certain pressure is relieved from complete system by opening nearest faucet to drain system. Shut off fuel supply to hot water heater.
- 3. Bypass & Connection Kit:** Locate the bypass valve and connect to the head assembly. Assemble the connection fittings and connect to the bypass valve. Tighten the connection nuts on both the bypass and connections fittings by hand only. Close both the inlet and outlet valves on the bypass and leave in closed position until instructed otherwise.
- 4. Plumbing Preparations:** Refer to diagram (Figure 2) for recommended plumbing procedure. Cut main supply line as required to fit plumbing to the inlet and outlet of neutralizer. Use thread tape on nipple threads, as most pipe thread pastes will cause deterioration of plastic fittings. Hold nipples with wrench while attaching plumbing. DO NOT OVERTIGHTEN. If a boiler drain (not supplied) is to be connected, be sure to install it on the outlet side of the ATUN Series Upflow Acid Neutralizer System.

**Note: All plumbing should be done in accordance with local plumbing codes.**

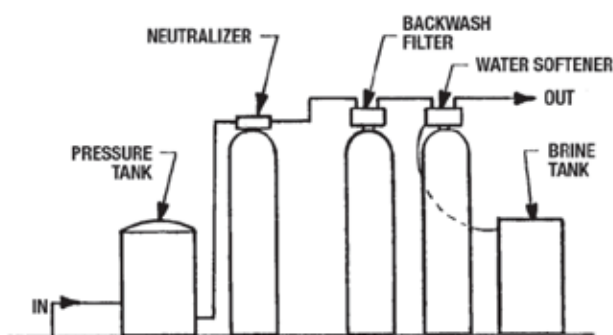
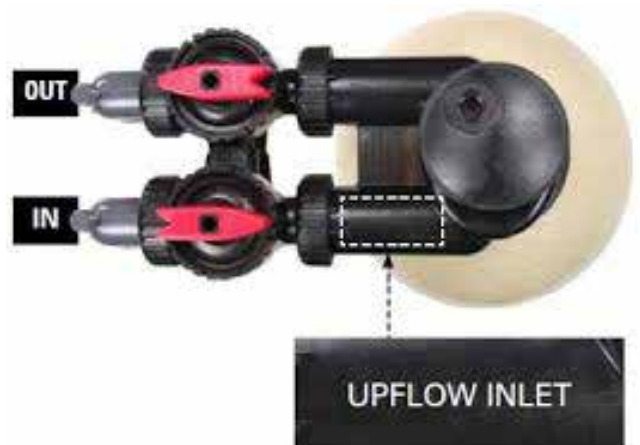

Figure 1. TYPICAL INSTALLATION SEQUENCE



## Installation CONT.

**5. Filling:** After completion of plumbing connections, remove fill-port cap using wrench provided and pour neutralizer media into mineral tank using funnel provided (see below). DO NOT fill tank above the line on the side of the media tank.

Overfilling the tank can result in neutralizer media entering the service lines. You may have been provide more media than is required for the initial fill. Save this extra media for future replenishment.

Open inlet valve and then turn water supply back on. Using a garden hose or bucket, fill unit with water through fill-port. Replace fill-port cap.

**6. Flush:** Attach a garden hose to boiler drain (if installed) on outlet of the ATUN Series Upflow Acid Neutralizer System. Discharge of hose should be into a bucket or drain. Open boiler drain and slowly open inlet valve to flush the ATUN Series Upflow Acid Neutralizer System. Discharge water from hose will be milky white due to fines generated during shipping and handling. Very fine particles of neutralizer media may also be observed in the water. If "sand" like particles are observed, reduce flush flow rate and then gradually increase. Continue to flush until discharge water runs clear. Upon completion of flushing, close boiler drain and bypass valve and open outlet valve

**7. IMPORTANT:** If the home utilizes a tankless water heater, it is recommended that a water softener be installed following the the ATUN Series Upflow Acid Neutralizer System. If the pH is initially over correct-ed, the inlet bypass can be partially closed to mix untreated water with treated water to achieve the desired level.



\*\*\*Disclaimer\*\*\* United Water strongly recommends that each system be installed by a licensed and knowledgeable professional. Failure to do so could result in property damage, equipment failure and potentially void warranty.



All systems MUST be installed in accordance with local and state plumbing codes.

## Mainternance & Replenishing/Filling MEDIA:

The media in this the ATUN Series Upflow Acid Neutralizer System is sacrificial, therefore it must be replenished periodically. The frequency is dependent on the raw water pH and your water consumption habits. The lower the pH and the higher the water usage, the more frequently replenishment will be required. One easy way of determining when to replenish is by placing a mark on the outside of the tank at the level of the media when first installed. Periodically shine a bright light through the tank and compare the current level to the mark, if it is down more than two (2) inches, add media to the mark. If you are unable to see through the tank, remove the fill-port cap and measure down to the top of the media. The tank should be 2/3 full. If not, add media.

- 1) Close inlet and outlet valves. Open bypass valve so untreated water can still be used during the replenishment operation.
- 2) Open boiler drain to relieve pressure. Remove fill-port cap using wrench provided, some water will drain out of the fill-port opening. Use a flexible tube to siphon approximately two gallons of water from the tank.
- 3) Using the funnel provided, add the required amount of media, not to exceed the indicated line on the media tank. A bright light may be placed behind the tank to observe the media level.
- 4) Refer to Steps 8-9 in Section 2 for flushing instructions to complete the replenishment operation.

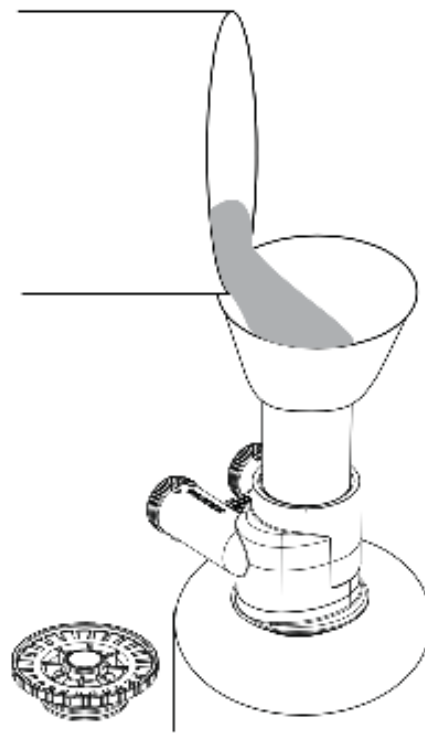
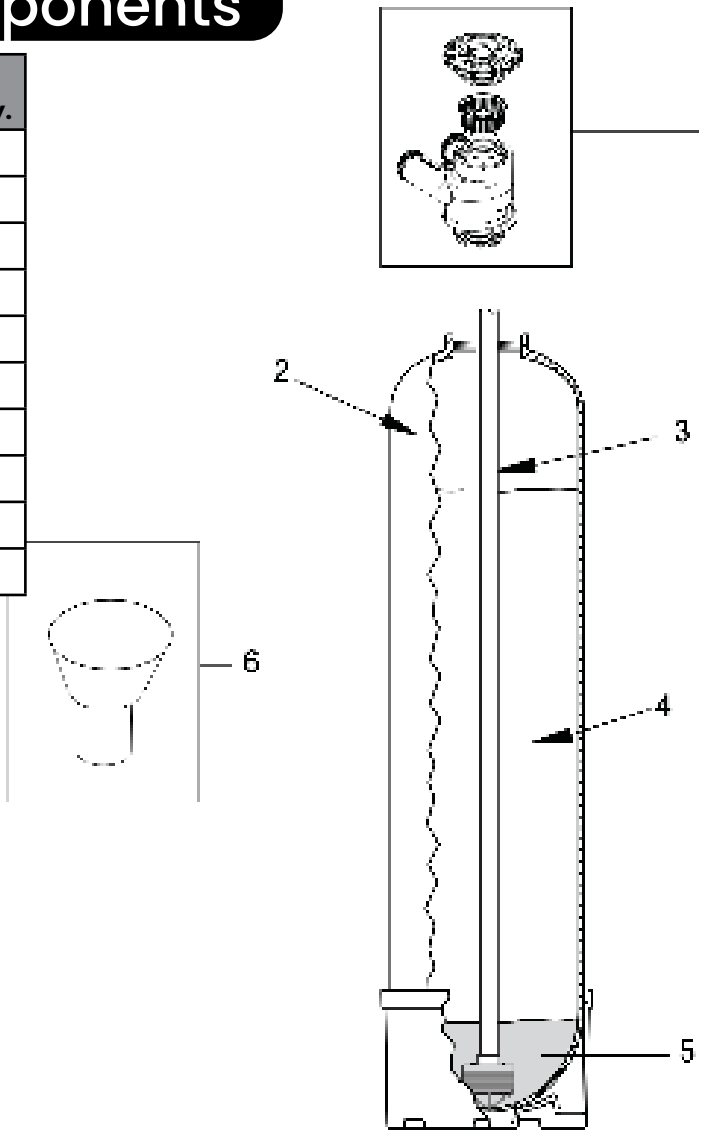

Figure 4. ADDITION OF NEUTRALIZER MEDIA

Add media through fill-port using funnel

# Parts & Components

Drawing Number	Part Number	Description	Qty.
1	CUFH-1190-FP	Upflow Head w/Fill-Port	1
2	AT-0948-N	ATUN1001 Mineral Tank	1
	AT-1252-N	ATUN1501 Mineral Tank	1
	AT-1252-N	ATUN2001 Mineral Tank	1
3	DT-65	Upflow Distributor Tube	1
4	MCPC-45-B	Media, Calcium carbonate	1
5	MGV20-12	ATUN1001 Gravel 1 cu ft Sys	1
	MGV20-15	ATUN1501 Gravel 1.5 cu ft Sys	1
	MGV20-25	ATUN2001 Gravel 2 cu ft Sys	1
6	F-25	Fill Funnel	1



## Bypass Assembly & Misc

Drawing Number	Part Number	Description	Qty.
n/a	V3006	Bypass Assembly (complete)	1
n/a	V3007-16	1" Male NPT Elbow (connection kit)	1
n/a	V3193-02	Wrench	1
1	V3151	1" Nut	2
2	V3150	Split Ring	2
3	V3105	O-Ring	2
4	V3145	1" Bypass Rotor	2
5	V3146	Bypass Cap	2
6	V3147	Bypass Handle	2
7	V3148	Bypass Rotor Seal Retainer	2
8	V3152	Bypass Cap O-Ring	2
9	V3155	Bypass Handle O-Ring	2
10	V3156	Bypass Rotor O-Ring	2

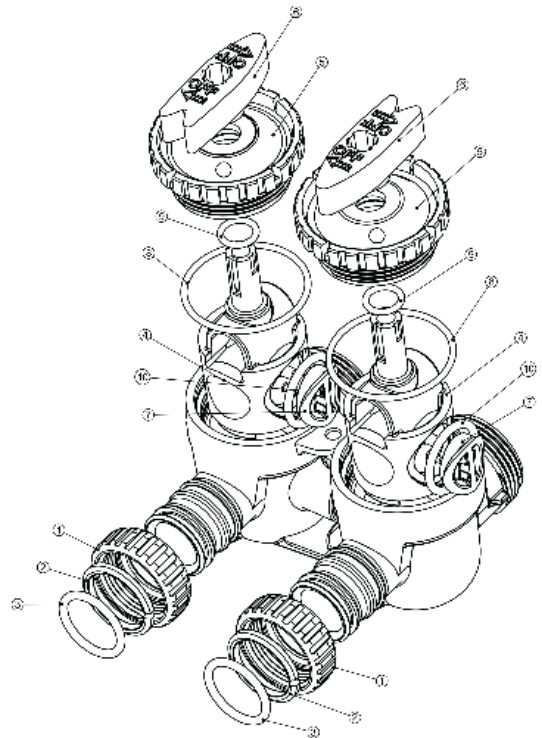



# Trouble Shooting Guide

Problem	Solution
<b>Neutralizer overcorrects upon installation or after replenishment</b>	The inlet bypass can be partially closed to allow untreated and treated water to mix to obtain desired pH level. Periodically test treated water pH and open bypass valve when pH begins to drop.
<b>Neutralizer fails to increase pH upon installation</b>	Make sure bypass valve is closed.
	Test water or have it tested via third party. If high hardness or total dissolved solids (TDS), seek alternate means of treatment such as feeding a solution of soda ash or caustic soda.
<b>Neutralizer fails to increase pH after being in service.</b>	Check filter bed for cementing or channeling. Break channeling or cementing with stiff rod or tubing.
<b>Excessive pressure drop.</b>	Check untreated water for sediment, silt or sand. Install sand trap or multiple cartridge filter prior to neutralizer.

## IMPORTANT SERVICING NOTE:

Under normal circumstances removal of the fill-port head assembly should not be required. However, if it must be removed, disconnect the plumbing attached to the bypass valve first. Then, rotate the fill-port head assembly to the left or counter-clockwise. Before attempting any disassembly, pressure should be relieved by shutting off water to the system and opening a faucet. Upon reassembly, all o-rings should be lubricated with silicone grease. Reattach fill-port head assembly by rotating to the right or clockwise until fill-port head assembly is seated to the tank hand tight. Reconnect the plumbing to the bypass valve.

# Manufacturer's Limited Warranty

The manufacturer warrants to the original owner that its Water Conditioning Equipment will be free from defects in material and workmanship under normal use and service for a period of five (5) years from the date of installation, when installed and operated within recommended parameters. No warranty is made with respect to defects not reported to Manufacturer within the warranty period and/or defects or damages due to neglect, misuse, alterations, accident, misapplication, physical damage, or damage caused by fire, floods, acts of God, freezing or hot water or similar causes. Manufacturer's obligation to the owner of this equipment under this Limited Warranty shall be limited, at its option, to replacement or repair of this Water Conditioning Equipment.

To obtain warranty service mail or ship the defective parts freight prepaid to the Manufacturer's place of business. Manufacturer will, at its option, repair or replace the defective components at its expense and return parts freight collect.

Manufacturer gives this warranty to the owner in lieu of all other warranties, express or implied, including without limitation any implied warranties of merchantability or fitness for a particular purpose and hereby expressly disclaims all other such warranties. Manufacturer's liability hereunder shall not exceed the cost of the product. Under no circumstances will Manufacturer be liable for any incidental or consequential damages or for any other loss, damage or expense of any kind, including loss of profits, arising in connection with the installation or use or inability to use this product.

To obtain warranty service contact:

## **United Water**

12427 NE 117th Ave Suite 105

Vancouver WA 98662

877-414-7873

[unitedwatercorp@gmail.com](mailto:unitedwatercorp@gmail.com)

[www.unitedwaterinc.com](http://www.unitedwaterinc.com)